



## XPR35 系列



- 单路输出
- 高可靠性，低功耗，高效率
- 全球电源宽范围输入
- 100%满负载老化
- 保护功能：过流/过载/短路保护
- 2 年质保

## 技术规格

指标(items)		型号(model)			
		XPR35-A-5	XPR35-A-12	XPR35-A-15	XPR35-A-24
输出	额定输出电压 (rated output voltage)	5V	12V	15V	24V
	输出电压范围 (input voltage range)	4.75V~5.25V	10.8~13.2V	13.5~16.5V	21.6~26.4V
	额定输出电流 (rated output current)	7A	3A	2.4A	1.5A
	额定输出功率 (maximum output power)	35W	35W	35W	35W
	最大纹波和噪声 (maximum ripple&noise)	50 mV	100 mV	100 mV	100 mV
	最大电压调整率 (maximum line regulation)	±2%	±1%	±1%	±1%
	最大负载调整率 (maximum load regulation)	±2%	±1%	±1%	±1%
维持时间 (hold-up time)		20ms/ 230V			
输入	效率(典型值) efficiency(typ)	70%	76%	78%	78%
	输入电压范围 (input voltage range)	85~264VAC			
	冲击电流 (inrush current)(typ)	20A/40A (AC115V/230V)			
保护	过流保护 (over current protection)	超过额定电流的 105%动作			
	过压保护 (over voltage protection)	在额定电压的 115%~150%动作			
绝缘	耐压 (withstand voltage)	输入(input)-输出(output)	1.5KVAC (10mA)		
		输入(input)-外壳(FG)	1.5KVAC (10mA)		
		输出(output)-外壳(FG)	500VAC (20mA)		
绝缘电阻 (isolation resistance)	输入(input)-输出(output)	500VDC >100MΩ			
	输出(output)-外壳(FG)	500VDC >100MΩ			
	输出(output)-外壳(FG)	500VDC >100MΩ			
环境	工作温度 (operating temperature)	-10~60℃ 参考降额曲线			
	贮藏温度 (storage temperature)	-20~75℃			
	贮存湿度 (storage humidity)	10~95%RH (无结露)			
参考标准	EMC 标准 (EMC standards)	满足(meet with) EN55011,EN55022 class B EN61000-3-2,3, EN61000-4-2,3,4,5,6,8,11			
	安全标准 (safety standards)	满足(meet with) UL60950, EN60950			
其它	冷却方法 (cooling)	自然冷却(convection cooling)			
	MTBF (h)	≥200,000			
	外型尺寸(size)	130*98*38 mm			



外形结构

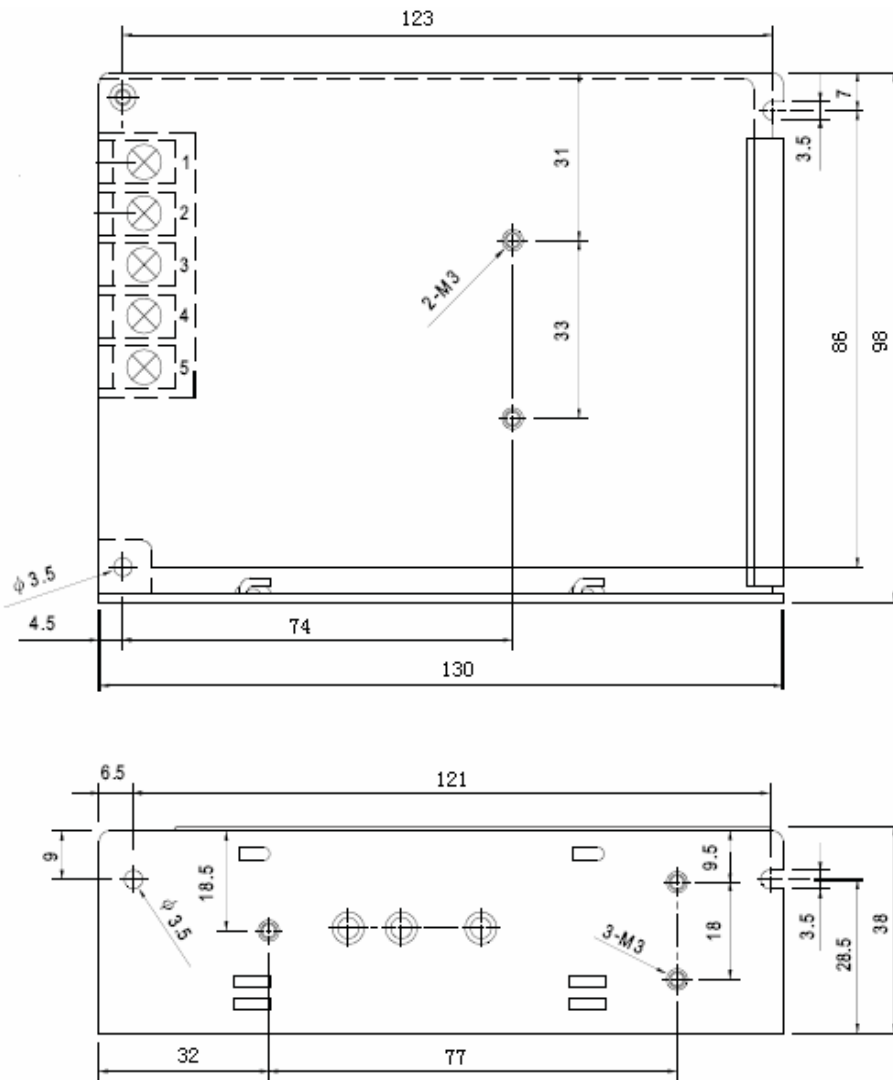

降额曲线

